

# LIQUID HANDLING



## PUMPS AND HIGH PRESSURE VALVES

### LIQUID HANDLING PUMPS, M SERIES

CE

The Cheminert® M Series liquid handling pump is a syringe-free pump capable of delivering a bidirectional flow over six orders of magnitude.

The M Series is a positive displacement pump, which means that it is self-priming and tolerant of any gas which may find its way into the fluid lines. There is no separate fill cycle, and the capacity is unlimited.

Two models are offered — the M6 with a flow range of 5 nl/min to 5 ml/min (10 ml/min intermittent), and the M50 with a range of 1 µl/min to 25 ml/min (35 ml/min intermittent). The M6 is also available in a high pressure model, rated to 1500 psi.

RS-232 and RS-485 communication protocols are incorporated into the microprocessor-driven controller.

The included software package controls flow rates, flow direction, and metered volumes.

#### Operating principle

At the core of the pump is a polymeric rotor housing four pistons in inert cylinders. As the microstepper motor turns the rotor, the pistons float on a stationary cam; at any given moment, one piston is filling, one is dispensing, and the other two are in transit between the fill and dispense positions.





## Liquid handling pumps

Prod No

<b>M6</b>		<b>5 nl to 5 ml range</b>
M6 pump with:	Controller and stepper motor	CP2-4841-F1
	Stepper motor (no controller)	CP2-4841-SF1
M6 pump only		CP2-4841-D
<b>M6HP</b>		<b>5 nl to 5 ml range</b>
M6HP pump with:	Controller and stepper motor	CP2-4841-F1-HP
	Stepper motor (no controller)	CP2-4841-SF1-HP
M6HP pump only		CP2-4841-D-HP
<b>M50 pumps</b>		<b>100 nl to 25 ml range</b>
M50 pump with:	Controller and stepper motor	CP3-8182-F2
	Stepper motor (no controller)	CP3-8182-SF2
M50 pump only		CP3-8182-D
<b>Accessories and replacement parts</b>		
Pump motor	M6	CP-DSM
	M6HP	CP-DSM
	M50	CP-DSM2
Controller	M-Force	CP-CMF
Standoff assembly*	2"	2SOAMPCCP
	3"	3SOAMPCCP
	4"	4SOAMPCCP
	6"	6SOAMPCCP

\* Adding a standoff will change the backlash. Consult factory for further information.



### OPTIONS

- Alternate materials for enhanced chemical resistance, biocompatibility, and lifetime.

Contact us for more information.

### APPLICATIONS

- Flow cytometry, cell and drug perfusion
- HTS and robotic systems
- Infusion and microdialysis
- Micro diluters/dispensers for nl to ml range applications
- Micro liquid transfers (nl) for micro arrays
- Microtiter plate dispensing using multiposition valves

### WATCH A VIDEO

The continuous fill/dispense design of this pump is demonstrated in a youtube video..



### TECH TIP

Use a standoff assembly if the motor must be separated from the pump head. Standoffs are available in lengths of 2", 3", 4", and 6".

### SPECIFICATIONS

	<b>M6</b>	<b>M6HP</b>	<b>M50</b>
Continuous minimum flow	5 nl/min	5 nl/min	100 nl/min
Continuous maximum flow	5 ml/min	5 ml/min	25 ml/min
Maximum back pressure	100 psi	1500 psi	100 psi
Gravimetric precision	for 125 µl	0.50%	0.80%
	for 1.25 ml	0.05%	0.10%
Pump internal volume (µl)	100 ± 2 µl	100 ± 2 µl	625 ± 10 µl

## Ultra-high pressure injector system



### LIQUID HANDLING

## 40,000 PSI ULTRA-HIGH PRESSURE INJECTOR SYSTEM

The VICI 40K injector is comprised of six miniature air actuated needle valves, plumbed to simulate the flow path of a conventional rotor/stator injector. An integral controller sends the on/off positioning signals to each valve, coordinating them to perform load, inject, and flush functions.

There are three methods for sending positioning commands to the injector:

- Manual control with the push buttons on the controller
- Laboratory computer via serial port communication
- Contact closure inputs

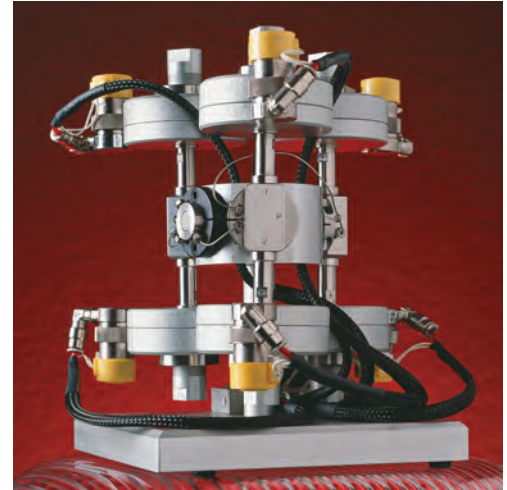

## Ultra-high pressure injector system

FOR LIQUIDS

Prod No

SPSS40

### SCHEMATIC DIAGRAM

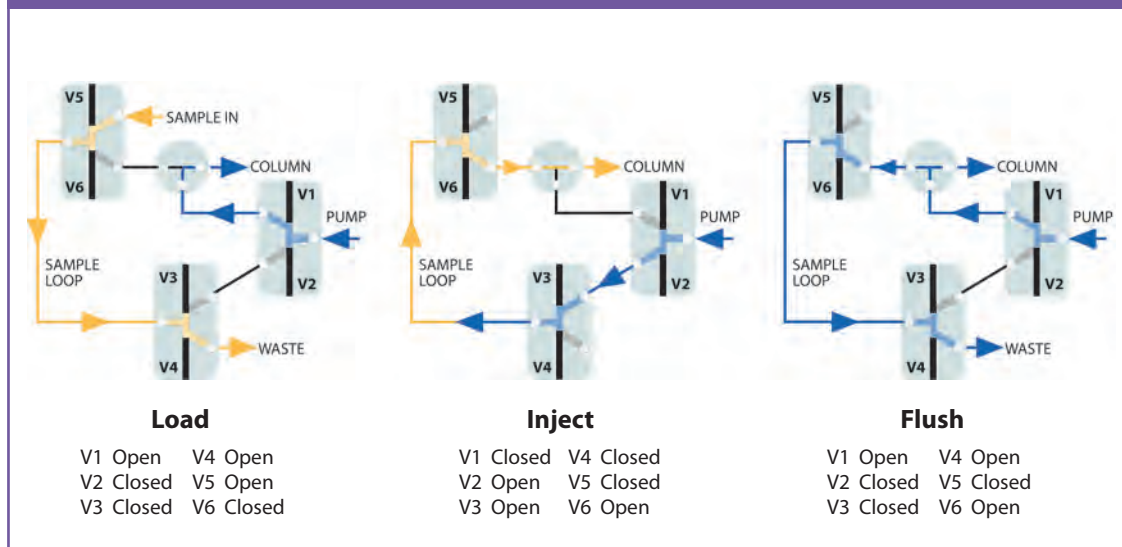

### DIMENSIONS



### TECH TIP

For more information, contact our technical department.



### 40,000 PSI ULTRA-HIGH PRESSURE VALVES

The ultra-high pressure valves that are the heart of our SPSS40 (previous page) are now available individually, in 1/16", 1/32", and 360 micron versions.

There are three types – a two port on/off valve, a dual on/off valve, and a 3-way prime/purge valve. (See page 198-63 for flowpath schematics.)

The dual on/off configuration has two individually controlled outlets with a common inlet (or vice versa), emulating a rotary three way valve.

Implementation requires a single three-way solenoid: application of 50 psi opens the valve; venting the air allows the spring to return the valve to the closed position. A fitting for 1/8" air supply tubing is included; two fittings are included for dual valves. (Fitting: prod no EAOR21, page 196.)

#### ON/OFF VALVE

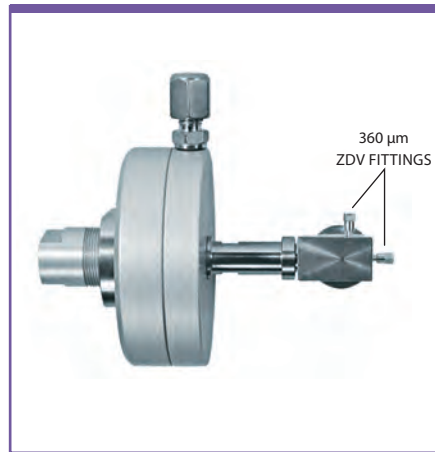

#### Ultra-high pressure valves

FOR LIQUIDS

Fittings Bore Prod No

On/off valves		
360 µm	0.15 mm	ASFVO40K360
1/32"	0.15 mm	ASFVO40K.5
1/16"	0.15 mm	ASFVO40K1
Prime/purge valves		
360 µm	0.15 mm	ASFV40K360
1/32"	0.15 mm	ASFV40K.5
1/16"	0.15 mm	ASFV40K1
Dual on/off valves		
360 µm	0.15 mm	ASFVOD40K360
1/32"	0.15 mm	ASFVOD40K.5
1/16"	0.15 mm	ASFVOD40K1

#### SPECIFICATIONS

**Pressure**  
40,000 psi liq  
**Temperature**  
50°C

#### PRIME/PURGE VALVE

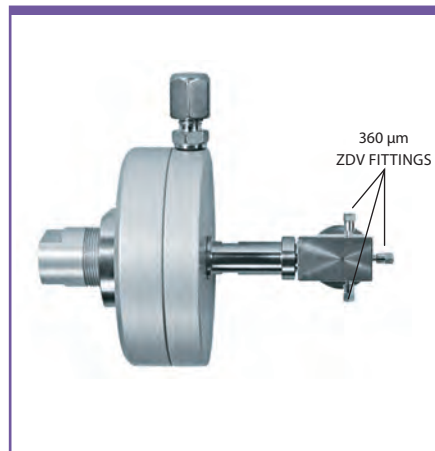

#### DUAL ON/OFF VALVES

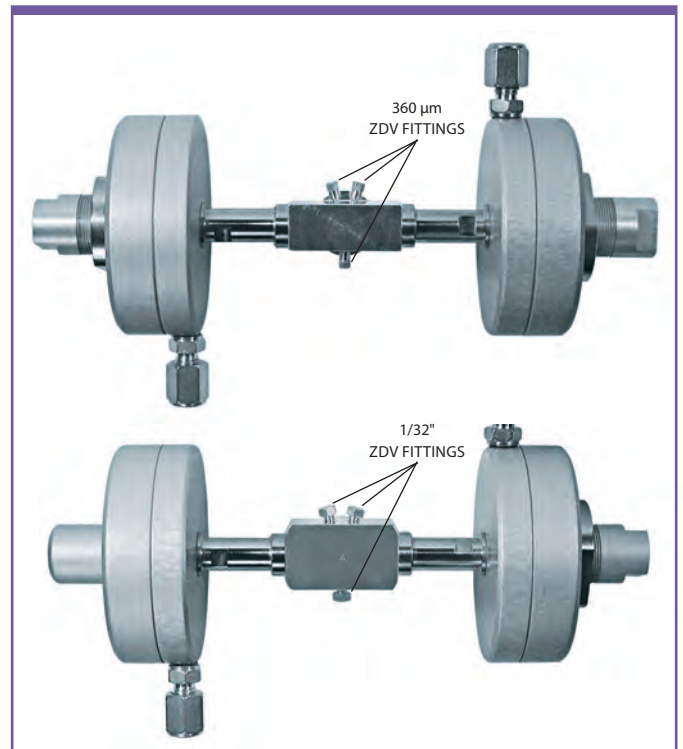

#### STANDARD ON/OFF AND PRIME/PURGE VALVES

2,000 psi to 10,000 psi valves . . . pages 198-199



#### TECH TIP

Three dual on/off valves comprise the ultra-high pressure injector system, SPSS40, on the facing page.